

LA-UR-19-25525

Approved for public release; distribution is unlimited.

Title: Validation of MCNP Rossi-alpha Calculations using Recent Measurements

Author(s): McKenzie, George Espy IV

Intended for: International Conference on Criticality Safety 2019, 2019-09-15
(Paris, France)

Issued: 2019-08-16 (rev.1)

Disclaimer:

Los Alamos National Laboratory, an affirmative action/equal opportunity employer, is operated by Triad National Security, LLC for the National Nuclear Security Administration of U.S. Department of Energy under contract 89233218CNA000001. By approving this article, the publisher recognizes that the U.S. Government retains nonexclusive, royalty-free license to publish or reproduce the published form of this contribution, or to allow others to do so, for U.S. Government purposes. Los Alamos National Laboratory requests that the publisher identify this article as work performed under the auspices of the U.S. Department of Energy. Los Alamos National Laboratory strongly supports academic freedom and a researcher's right to publish; as an institution, however, the Laboratory does not endorse the viewpoint of a publication or guarantee its technical correctness.

Validation of MCNP^{®1} Rossi-alpha Calculations using Recent Measurements

George McKenzie ^{(1)*}

⁽¹⁾Los Alamos National Laboratory, PO Box 1663 Los Alamos, NM 87545

* gmckenzie@lanl.gov

ABSTRACT

This work will focus on the correct usage and validation of the MCNP KOPTS, kinetics options, card to obtain Rossi- α , or prompt neutron decay constant, for a system. The validation will focus on recent prompt neutron decay constant measurements completed at the National Criticality Experiments Research Center (NCERC) with comparison to both benchmark level and best working MCNP input decks. Measurements performed on Polyethylene Class Foils, HEU Zeus, HEU/Pb Zeus, IEU/Pb Zeus, KRUSTY, and Jupiter will be compared to their respective calculations. The prompt neutron decay constant measurements cover an energy spectrum of fast to thermal and two major fissionable isotopes, Uranium-235 and Plutonium-239, with different reflectors and interstitial materials. For each of these experiments, prompt neutron decay constant measurements are performed on several subcritical configurations. The Rossi- α , or prompt neutron decay constant at delayed critical, is always extrapolated from subcritical measurements, but in some cases direct measurements of the prompt neutron decay constant are taken at delayed critical. For the simulations performed in this work, the best available input deck is used to calculate the value of the prompt neutron decay constant at delayed critical. This paper will stress the importance of closely matching the critical configuration of the experiment when obtaining a result from the KOPTS card. This is due to the method in which the code calculates the prompt neutron decay constant. An explanation of this methodology is included. Based on the results included in this work, the KOPTS card in MCNP has a tendency to over-predict the prompt neutron decay constant by about 10 %.

KEY WORDS

Rossi- α , Neutron Noise, Validation

1. INTRODUCTION

This paper focuses on the correct usage and validation of the MCNP KOPTS [1], kinetics options, card to obtain the prompt neutron decay constant at delayed critical. The KOPTS card can turn on the codes kinetics options which has additional parameters tracked during execution such as: the Rossi- α , the generation time, and the effective neutron fraction. The validation will focus on recent measurements of the prompt neutron decay constant completed at the National Criticality Experiments Research Center (NCERC). Previous validation of this capability was performed by Mosteller and Kiedrowski in 2011 [2]. Their validation consisted of comparison of results to established historical data, this work will expand on their contribution by introducing additional validation points on systems measured since 2011.

The measurements used for validation in this work were performed on a variety of systems with varying average neutron energy using two fissile nuclides, including Uranium-235 (²³⁵U) and Plutonium-239 (²³⁹Pu), as a fuel source. The systems discussed in this work include: The Polyethylene Class Foils, HEU Zeus, HEU/Pb Zeus, IEU/Pb Zeus, KRUSTY, and Jupiter. These measurements have been previously documented

¹ MCNP[®] and Monte Carlo N-Particle[®] are registered trademarks owned by Triad National Security, LLC, manager and operator of Los Alamos National Laboratory. Any third party use of such registered marks should be properly attributed to Triad National Security, LLC, including the use of the designation as appropriate. For the purposes of visual clarity, the registered trademark symbol is assumed for all references to MCNP within the remainder of this paper.

in ANS Transitions, but many do not include simulation results. This paper seeks to do a validation between the measured data and the simulated kinetics parameters.

For each of the experiments, the prompt neutron decay constant at delayed critical was either directly measured or extrapolated from several subcritical data points. In some cases the experiment and simulation model will have undergone significant enough peer review to be considered a criticality safety benchmark by the Nuclear Energy Agency (NEA). Several of the input decks included in this work are either already included in the International Handbook of Evaluated Criticality Safety Benchmarks (ICSBEP) [3] and others included use a draft of a benchmark input. In all cases, the best available input deck is used to simulate the kinetics parameters. These static k-eigenvalue simulations are chosen for comparison because the typical usage of the MCNP *KOPTS* card is to receive kinetics information from a k-eigenvalue calculation.

Measurements of prompt neutron decay constants have a variety of uses including: in situ measurements, improvements in nuclear data, determination of system mass, and determination of the hardness of the neutron spectra in a particular system. Many of these applications are useful to the realm of criticality safety, but the use of neutron noise measurement techniques to improve nuclear data is one of the most important. As new fission models are introduced into codes it becomes increasingly important to ensure our models produce the correct nuclear kinetics parameters.

2. SYSTEM DESCRIPTIONS

a. Polyethylene Class Foils

The Polyethylene Class Foils is a thermal spectrum, metal HEU system designed to be at the minimum critical mass for a heterogeneous system. The critical mass of the Class Foils experiment using polyethylene interstitial is 997.9 ± 0.65 g [4]. The Polyethylene Class Foils experiment consists of a stacking of 22.9-cm square by 76.2- μm (9.0-in. square by 0.003-in.) thick ^{235}U foils. These foils consist of thin highly enriched uranium (93-wt% ^{235}U) metal foils laminated in plastic; each foil weighs nominally 68-g. The interstitial material is 35.6-cm square by 1.27-cm (14.0-in. square by 0.500-in.) thick polyethylene plates with a 25.718-cm square by 660- μm (10.125 in. square by 0.026-in.) deep recession machined into them to hold the ^{235}U foil in place.

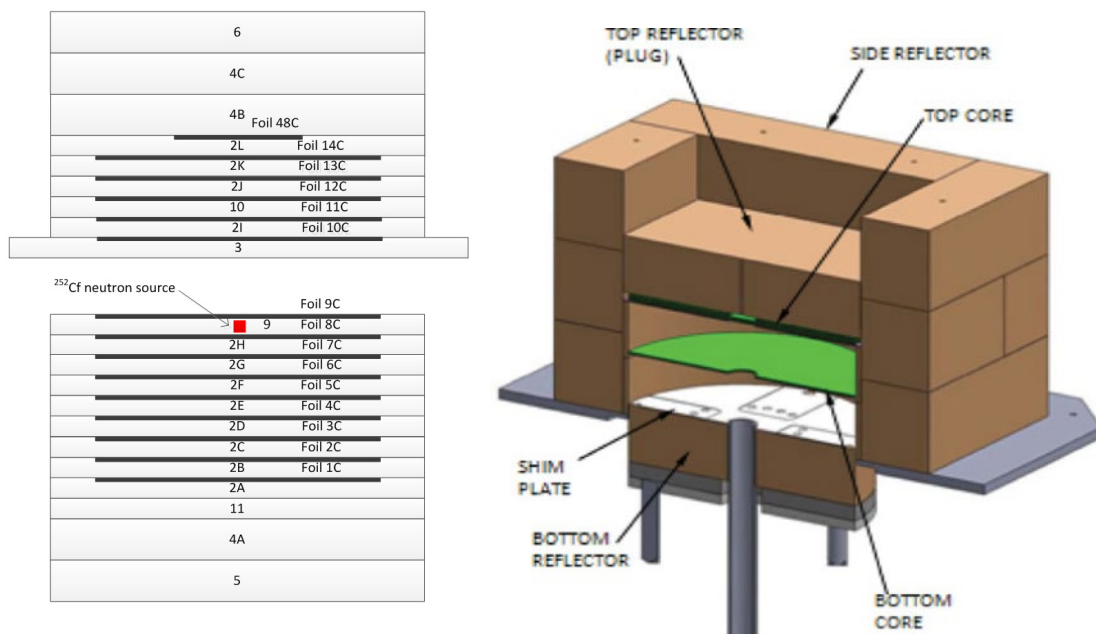

Figure 1. LEFT: Stacking of the Polyethylene Class Foils. RIGHT: The all HEU Zeus assembly.

b. HEU Zeus

HEU Zeus is a copper reflected, uranium metal system designed to not significantly soften the neutron spectrum of neutrons reflected back into the system helping reduce the system size for intermediate energy assemblies. The Zeus series of experiments consists of a cylindrical core region that is surrounded on all sides by a metallic copper reflector [5]. The core is divided into an upper portion and a lower portion. The upper portion rests on a thin, square stainless steel plate, called a diaphragm. The bottom portion of the core sits on the top of the bottom reflector. The bottom reflector, in turn, sits on the movable platen of the Comet vertical assembly machine as illustrated in Figure 1. The lower portion of the core is held in position by a central, hollow aluminum alignment tube. The top, corner, and side reflectors rest on a stationary aluminum plate attached to the Comet machine.

The experiment is assembled by raising the bottom portion of the assembly into a blind hole until it makes full contact with the steel diaphragm that supports the top portion of the core. The top portion of the core consisted of six highly enriched uranium (HEU) metal units. The bottom portion of the core consisted of two HEU metal units plus a 0.3175-cm thick aluminum metal shim. Each HEU metal unit used in these experiments had two components, an inner disk and an outer ring. All the HEU plates are nominally 0.300-cm (0.118-in.) thick. The inner disks are 38.1-cm (15.0-in.) in diameter. The inner disks in the bottom portion of the core had a 6.35-cm (2.50-in.) diameter central hole to accommodate the alignment tube. In contrast, the inner disks in the top portion of the core are solid pieces of HEU. The outer rings are approximately 53.3-cm (21.0-in.) OD and 38.1-cm (15.0-in.) ID. The uranium plates are on average 93.22 wt% ^{235}U , 1.11 wt% ^{234}U , and 5.67 wt% ^{238}U . The aluminum shim was placed between the bottom copper reflector and the bottom HEU metal unit as illustrated in Figure 1.

c. HEU/Pb Zeus

HEU/Pb Zeus is a copper reflected, lead interstitial, uranium metal system maximizing fission in the intermediate energy range. The copper outer reflector and HEU plates are identical to the materials used in the HEU Zeus experiment. The HEU/Pb Zeus experiments modified the definition of a “unit” in comparison to the HEU Zeus experiment to include lead plates interleaved between the HEU plates as shown in Figure 2.

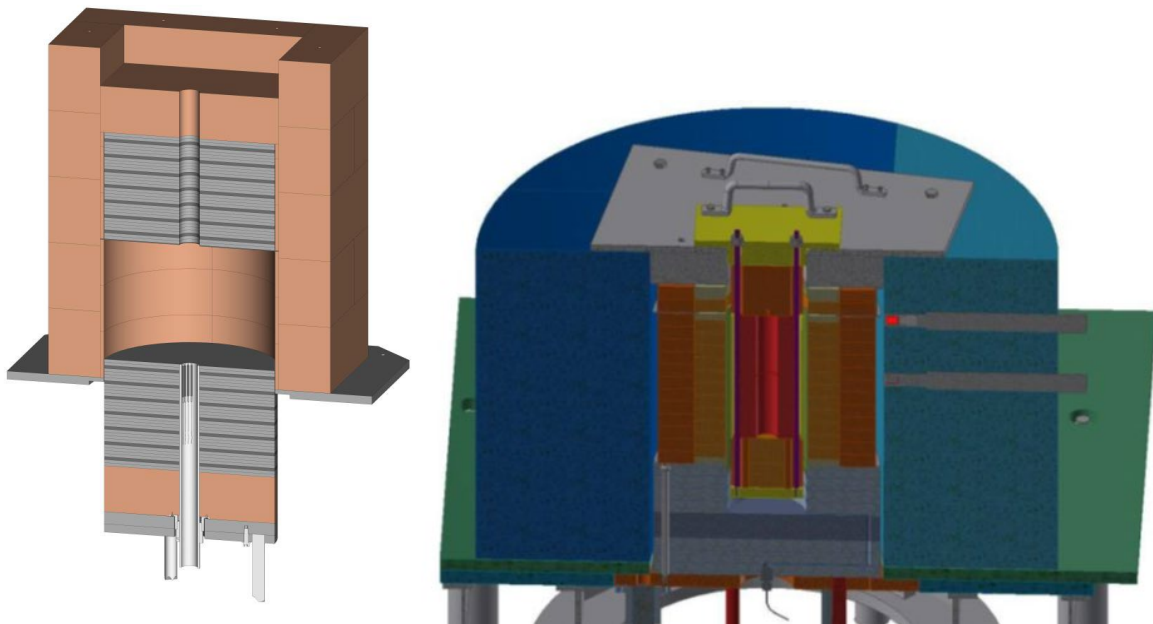

Figure 2. LEFT: Picture of the HEU/Pb Zeus assembly. RIGHT: KRUSTY component critical configuration.

In the HEU/Pb Zeus configuration, the top portion of the core contains seven HEU plates plus one smaller HEU plate. The bottom portion of the core also contains seven HEU plates plus a smaller HEU plate. The seven full units are shown in Figure 2, but the smaller HEU plates are not included in this figure. In both

portions of the core, each HEU plate are surrounded by four lead plates, two above and two below the HEU plate. Each lead plate for this configuration is sandwiched by thin aluminum shims used to reduce cross contamination. These shims are 0.079-cm (0.031-in.) thick and the overall lead/aluminum stack was 0.615-cm (0.242-in.) thick. In addition to the HEU plates described in the HEU Zeus experiment, some additional HEU is used in this core [6].

d. IEU/Pb Zeus

IEU/Pb Zeus is an attempt to reproduce the HEU/Pb Zeus measurements with a lower fuel enrichment. These measurements use the same HEU plates, lead plates, and copper reflector set that the HEU/Pb Zeus experiment used. The major addition to this series are a set of natural uranium plates which are interleaved with the HEU plates to reduce the effective enrichment to just above 20 % ^{235}U . The natural uranium plates have identical radial dimensions to the HEU plates, but come in two different thicknesses measuring 1.52-cm (0.598-in.) and 1.21-cm (0.477-in.). No image of the IEU/Pb Zeus experiment are included because of its similarity to the HEU Zeus and HEU/Pb Zeus experiments.

e. KRUSTY

The KRUSTY critical experiment is a joint collaboration between Los Alamos National Laboratory, NASA, and Y-12. The reactor is designed to provide fission energy to increase the temperature differential between the “hot” and “cold” ends of the heat pipes which in turn drive Stirling engines. The reactor itself consists of highly enriched uranium (HEU) fuel reflected by beryllium oxide (BeO). The prototype version also has a stainless steel bio-shield which provides additional reflection. The stainless steel shield is expected to reduce leakage, but not greatly impact the spectrum of the system or alter the neutronic properties of the assembly [7].

The KRUSTY project consists of a four phase implementation/testing of the system at the National Criticality Experiments Research Center (NCERC). The first phase tests the fuel and reflector set with all of the other equipment replaced by an aluminum hanger. The second phase repeats the first phase with the addition of the heat pipes, vacuum chamber, and electrical generation equipment. Phase three is the incremental increase in heat generation and characterization of the system response to temperature. The fourth and final phase is a full power (~800 °C) 28 hour test which included examining several transient scenarios [7]. Prompt neutron decay constant measurements are performed on the first phase of the experiment. A drawing of the KRUSTY critical experiment during the first phase is included in Figure 2.

f. Jupiter

The Jupiter experiment is designed to measure the lead void reactivity coefficient associated with an intermediate plutonium system. The Jupiter critical experiment consists of a copper reflector set most notably used in the Zeus experiment series [8]. The fuel used during the Jupiter experiments consists of small plutonium plates most notably used at Idaho National Laboratory as part of the Zero Power Physics Reactor (ZPPR). These plates are nominally 7.6-cm by 5.1-cm by 0.318-cm (3.0-in. by 2.0-in. by 0.125-in.). The system is designed using aluminum boxes, shown in Figure 3, meant to mimic the drawers used in ZPPR. Between the plutonium fuel plates, lead moderator plates are placed. To minimize lead contamination on the surrounding fuel, aluminum shims are placed on either side of the lead. The lead plates and aluminum shims had rectangular dimensions of 7.6-cm by 5.1-cm (3.0-in. by 2.0-in.), but each had a different thickness equal to 1.20-cm (0.473-in.) and 1.93-cm (0.076-in.) respectively.

The critical system consisted of 80 of these boxes arranged in three layers. A photo of the top layer is included in Figure 3. To make the system more spherical in shape, the boxes in the corners were replaced with copper blocks to produce a pseudo-sphere. To adjust reactivity, low worth plates were removed from several outside units in the bottom layer producing several partial boxes. Another point of interest are the inclusion of aluminum pieces to decrease gaps between the boxes in the middle and bottom layer. These pieces are added to reduce movement and increase repeatability between configurations [8]. Shims are not added to the top layer because reconfiguring the top layer would have cost significant time and these units are not expected to sufficiently move.

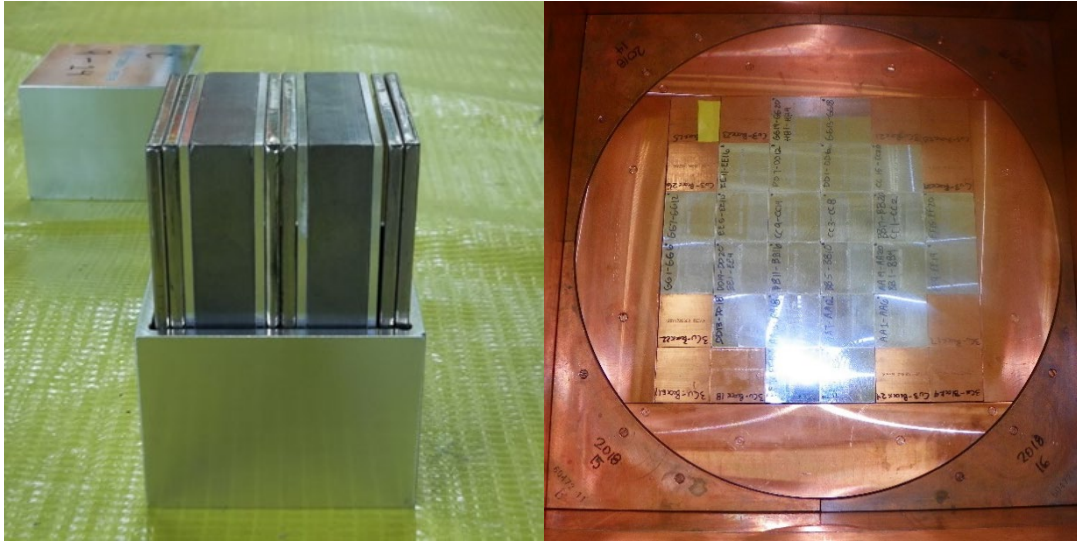

Figure 3. LEFT: Jupiter fuel box. RIGHT: Top down view of top layer of the Jupiter experiment.

3. RESULTS

This section will highlight the results from the experiment and subsequent simulations of each of the assemblies described in Section 2. For each experiment, an experimental setup description and result of the prompt neutron decay constant at delayed critical is given. Additionally, a short description of the level of detail included in the model, the version of MCNP used, and the cross section set used is given along with the simulation result.

Prompt neutron decay constant measurements are performed by measuring the temporal distribution of neutron detection events to infer other reactor kinetics parameters of interest. The measurement itself gives the rate at which the prompt neutron population in a system changes. For all systems below prompt critical, this rate is a decay. The decay rate can be measured in several ways, but this paper discusses measurements using the Rossi- α method. The Rossi- α method measures a static object and generates a decay histogram, like the example shown in Figure 4, based on the measured neutron fluctuations [9]. References [9] and [10] include more detailed derivation of the Rossi- α method. The only dead-time mitigation used for these measurements is the use of multiple detectors to reduce overall system dead-time. Statistical methods to “replace” counts on short timescales are deemed unnecessary on the systems discussed in this work as realistically only one or two of the early time bins is affected by detector dead-time. These statistical methods are more necessary on systems with shorter neutron lifetimes.

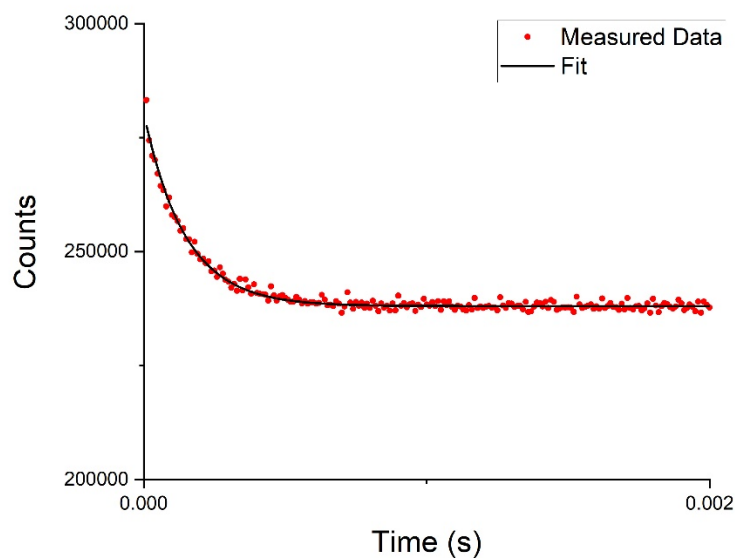

Figure 4. Example of the Rossi- α decay histogram.

The prompt neutron decay constant can either be directly measured or linearly extrapolated from several subcritical measurements. Using the measured subcritical values and the inverse of the detector count-rate for each measurements, the prompt neutron decay constant at delayed critical can be determined using the fact that delayed critical is defined as infinite multiplication [10]. So, as the inverse of the count-rate approaches zero, the value of alpha approaches the value of alpha at delayed critical. An example using data from the Polyethylene Class Foils experiment is shown in Figure 5.

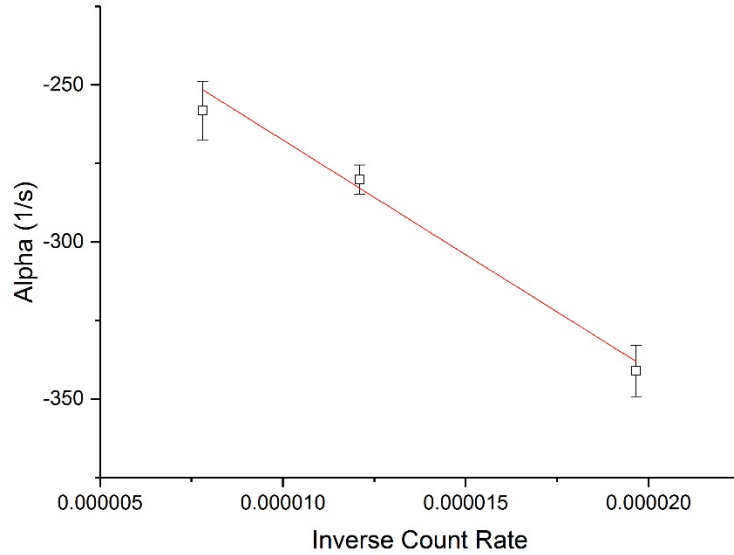

Figure 5. Example of the linear extrapolation of alpha at delayed critical.

All of the results presented in this section are measurements or inferences of the prompt neutron decay constant at delayed critical, each result will herein only be described as the system alpha. For each simulation performed, an attempt is made to exactly match the critical configuration obtained during the experiment. Matching the critical configuration from the experiment is important because the *KOTPS* card in MCNP returns a value for alpha based on the calculated value of the neutron lifetime and effective delayed neutron fraction, rather than tracking the decay of prompt neutrons directly. The relationship between alpha, neutron lifetime and the effective delayed neutron fraction at delayed critical is shown in Eq. 1. This definition is derived from Eq. 2 with an approximation that k_p at delayed critical is equal to $1-\beta$.

$$\alpha_{DC} = \frac{-\beta}{l} \quad (1)$$

$$\alpha = \frac{k_p - 1}{l} \quad (2)$$

For the result from the simulation to be meaningful, the simulated estimation of the neutron lifetime and effective delayed neutron fraction must be accurate. The best way to maintain accuracy is to attempt to produce a model that has a k_{eff} very near one. For these measurements, a critical configuration is known, so that configuration is used. This is important when trying to replicate subcritical measurements of alpha. Another method must be used which is both time intensive and computationally expensive [10].

g. Polyethylene Class Foils

The value of the prompt neutron decay constant at delayed critical for the Polyethylene Class Foils experiment was determined from a multitude of subcritical measurements. These measurements were taken with 4 He-3 detectors placed inside a special polyethylene plate. This plate allowed the detection system the access to

measure the centermost flux. An attempt was made to place the detection system in the centermost unit, but this was not always possible. This experiment is possibly one of the best characterized experiment of all discussed in this work. The measured value of alpha for the Polyethylene Class Foils is $-199.4 \pm 4.4 \text{ s}^{-1}$ [11].

The MCNP deck used for the Polyethylene Class Foils analysis was in its infancy in terms of benchmarking. The level of detail is rather simplistic in comparison to a full-fledged benchmark. Although the detail is lacking, the determined value is rather close to the measured value. The value of alpha simulated for the Polyethylene Class Foils using MCNP 6 and ENDF/BVII.1 cross sections is $-204 \pm 13.6 \text{ s}^{-1}$ [11].

h. HEU Zeus

The HEU Zeus experiment had prompt neutron decay constant measurements performed using 4 He-3 tubes placed in the radial center of the core. The tubes were placed inside the spindle of the assembly which is an aluminum tube designed to center and support the fuel pieces on the moveable platen. For this configuration, the system was not axially centered because more than half of the fuel resided above the diaphragm and the tubes were taller than the axial height of the core, but this positioning was the nearest to the center of the core that the measurement system could be. The directly measured value of alpha for this experiment is -90408.4 s^{-1} . No uncertainty was calculated on this result. The inferred value of alpha is $-89909.9 \pm 816.9 \text{ s}^{-1}$ [12].

The MCNP deck used for the HEU Zeus analysis is the benchmark model included as HEU-MET-FAST-073 [3]. This model was created previous to the prompt neutron decay constant measurements. The simulated value of alpha for HEU Zeus using MCNP5 and ENDF/BVI.8 cross sections is $-100048 \pm 0.584 \text{ s}^{-1}$ [12].

i. HEU/Pb Zeus

The HEU/Pb Zeus experiment had a very similar setup to the HEU Zeus experiment, and the detectors were put inside the spindle in the same location. The only key difference is that because more of the fuel for HEU/Pb Zeus was placed on the platen than above the diaphragm, the detectors were able to be both radially and axially centered in the core. The measured value of alpha for this system is $-38255.2 \pm 324.8 \text{ s}^{-1}$ [6].

The MCNP deck used for the HEU/Pb Zeus analysis is the deck which will be presented as a new benchmark in 2019. This model has the full detail of a modern benchmark and is expected to be included in the next release of the ICSBEP handbook [3]. This input still has been calculating with a larger effective multiplication factor than expected which may lead to a larger discrepancy to the measurement. The simulated value of alpha for the HEU/Pb Zeus experiment using MCNP 6 and ENDF/BVIII.0 cross sections is $-46256.4 \pm 901.1 \text{ s}^{-1}$.

j. IEU/Pb Zeus

The IEU/Pb Zeus experiment had a very similar setup to both the HEU Zeus and the HEU/Pb Zeus. The detection system for this experiment was placed in the same location in the spindle as for HEU/Pb Zeus, and was centered both radially and axially in the core. This system was expected to have a harder neutron spectrum than that of the HEU/Pb Zeus core because there is more uranium per unit volume in this core. As expected the measured value of alpha was harder than the HEU/Pb Zeus value, the value for the IEU/Pb Zeus experiment is $-56350.4 \pm 552.4 \text{ s}^{-1}$.

The MCNP deck used for the IEU/Pb Zeus analysis is the deck which will be presented as a new benchmark in 2019. This model has the full detail of a modern benchmark and is expected to be included in the next release of the ICSBEP handbook [3]. The simulated value of alpha for the IEU/Pb Zeus experiment using MCNP 6 and ENDF/BVIII.0 cross sections is $-62286.2 \pm 1157.5 \text{ s}^{-1}$.

k. KRUSTY

The KRUSTY critical experiment had prompt neutron decay constant measurements performed using 4 He-3 tubes placed in the heat pipe channels of the core. Although there was a central cavity in the fuel, there was unfortunately no way to instrument detectors into this location. The heat pipe channels provided a convenient location to place the detection system around the fuel. Because of this positioning, the system had many reflected neutrons incident upon it which led to saturation of the detectors from what are in essence source neutrons near critical, so no direct measurement was attempted. The measured value of alpha for the KRUSTY

experiment is $-1136.5 \pm 16.1 \text{ s}^{-1}$. This result differs slightly from the result published at ANS Winter Meeting 2018 [7] because some of the analysis was in preliminary form.

The MCNP deck used for the KRUSTY analysis is the deck used to design the experiment. Normally this input deck would be somewhat simplified, but for KRUSTY that was not the case. This input deck is very detailed and could potentially become a benchmark with little to no additional detail. This level of detail in planning is driven by the fact that the experiment, and its simulations, were required to be extremely well known before a full power test could be completed. The simulated value of alpha for KRUSTY using MCNP 6 and ENDF/BVIII.0 cross sections is $-1201.1 \pm 19.3 \text{ s}^{-1}$.

1. Jupiter

The Jupiter experiment consisted of layers of aluminum boxes which contained plutonium and lead. There was no central cavity in which to place a detection system, but there was a 6.35-cm (2.5-in.) hole bored into the top copper reflector. This location was the only direct line of sight to the fuel, so the detection system was placed inside this hole. The measured value of alpha for the Jupiter experiment is $-17312.8 \pm 238.7 \text{ s}^{-1}$ [8].

The MCNP deck used for the Jupiter analysis is the deck which will be presented as a new benchmark in 2019. This model has the full detail of a modern benchmark and is expected to be included in the next release of the ICSBEP handbook [3]. The simulated value of alpha for Jupiter using MCNP 6 and ENDF/BVII.1 cross sections is $-19295.2 \pm 1194.0 \text{ s}^{-1}$.

4. INTERCOMPARISON

This section will compare the results obtained above for individual experiments, and discuss overall trends for the data. Table I includes all of the measured and simulated values of alpha for each of the experiments discussed in Section 3. Table I also includes the comparison of the values through (C-E)/E. The values of (C-E)/E for each case are plotted along with a line of perfect agreement in Figure 6. As in Mosteller and Kiedrowski's work, the simulations presented tend to over-predict the value of alpha at delayed critical between 2 % and 20 %.

Table I. Prompt neutron decay constant comparison.

Experiment	Measured (s^{-1})	Simulated (s^{-1})	(C-E)/E
Polyethylene Class Foils	-1.994 E2	-2.040 E2	0.0231
HEU Zeus	-8.991 E4	-1.000 E5	0.1128
HEU/Pb Zeus	-3.826 E4	-4.626 E4	0.2092
IEU/Pb Zeus	-5.635 E4	-6.229 E4	0.1053
KRUSTY	-1.136 E3	-1.201 E3	0.0568
Jupiter	-1.731 E4	-1.930 E4	0.1145

The U-235 and Pu-239 cases presented by Mosteller and Kiedrowski had (C-E)/E differing less than 1 % to 35 %. The case which had 35 % disagreement seemed to be an outlier as all other experiments fell below 12 % disagreement as demonstrated in Table II. All but one case validated by Mosteller and Kiedrowski, experienced the same over-prediction trend. All of the (C-E)/E values are also plotted in Figure 6.

Table II. Prompt neutron decay constant comparison from Mosteller and Kiedrowski [2].

Experiment	Measured (s^{-1})	Simulated (s^{-1})	(C-E)/E
Godiva	-1.11 E6	-1.13 E6	0.0180
Flattop-25	-3.82 E5	-3.96 E5	0.0366
Zeus-1	-3.38 E3	-3.80 E3	0.1243
Zeus-5	-7.96 E4	-1.08 E5	0.3530

Zeus-6	-3.73 E4	-4.19 E4	0.1233
Jezebel	-6.40 E5	-6.40 E5	0.0000
Flattop-Pu	-2.14 E5	-2.08 E5	-0.0280
Thor	-1.90 E5	-1.90 E5	0.1053

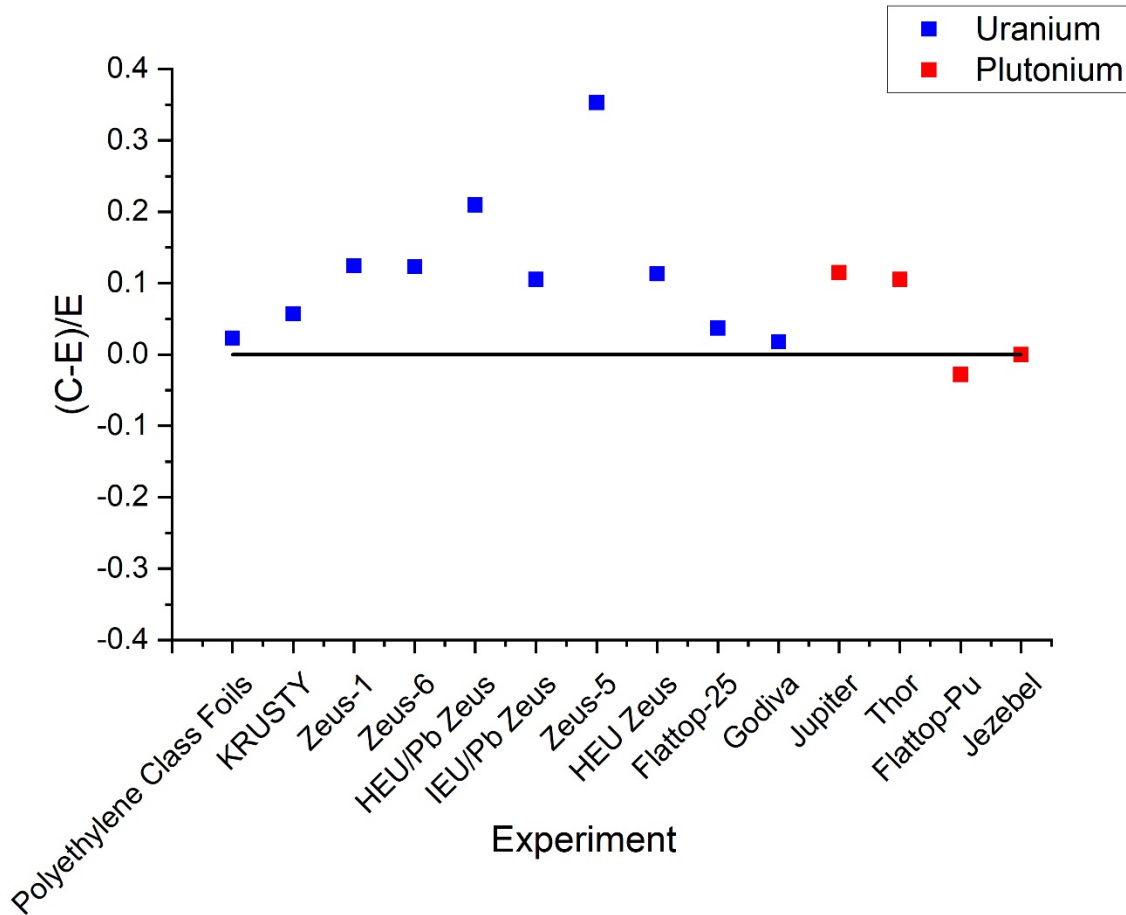

Figure 6. $(C-E)/E$ comparison for all systems in Table I and II.

Overall, it seems that simulated results from the *KOPTS* card in MCNP tend to over-predict the prompt neutron decay constant at delayed critical. This over-prediction seems to be near 10% for most cases. Simple cases where the nuclear data for the materials used is well-known, tend to have improved agreement between measurements and simulations. Cases more complexity or materials with less well-known nuclear data tend to have more disagreement than 10%. This type of analysis can be used to highlight materials where nuclear data improvements may be required.

5. CONCLUSIONS

Six new experiments have been included as new validation cases for the MCNP *KOPTS* card. These experiments include the Polyethylene Class Foils, HEU Zeus, HEU/Pb Zeus, IEU/Pb Zeus, KRUSTY, and Jupiter. One of these six has already been included in the ISCBEP handbook as a benchmark, and the other five are expected to be added in the near future. The percent differences from the six new experiments trend well when compared to previous validation. For all new cases and all but one case from the previous validation, the simulated value over-predicted the prompt neutron decay constant at delayed critical. Most of the over-predictions are on the order of 10% greater than the measured value. Simple systems containing few materials or materials with well-known cross sections tend to out-perform 10%, while a more complex system may under-perform the 10% trend.

ACKNOWLEDGMENTS

This work was supported in part by the DOE Nuclear Criticality Safety Program and by the DOE Office of Material Management and Minimization and by the DOE Nuclear Criticality Safety Program, funded and managed by the National Nuclear Security Administration for the Department of Energy.

The author would also like to acknowledge all experimentalists, engineers, scientists, and support personnel who made the work possible. The author would also like to acknowledge Theresa Cutler, Russ Mosteller, Kelsey Amundson, Akito Oizumi, Dave Poston, and Alex McSpaden who spent many hours developing the high fidelity models during benchmarking.

REFERENCES

- [1] T. Goorley, et. al., “Initial MCNP6 Release Overview,” *Nuclear Technology*, **180**, pp. 298–315 (2012).
- [2] R. Mosteller and B. Kiedrowski, “The Rossi Alpha Validation Suite for MCNP,” *Proceeding of ICNC 2011*, Edinburgh, Scotland.
- [3] *International Handbook of Evaluated Criticality Safety Benchmark Experiments*, Nuclear Energy Agency, Boulogne-Billancourt, France (2018).
- [4] T. Cutler, J. Bounds, T. Grove, J. Hutchinson, D. Hayes, and R. Sanchez, “A new critical experiment in support of the nuclear criticality safety class,” *Proceeding of ICNC 2015*, Sun Valley, Idaho.
- [5] R. Sanchez, J. Bounds, T. Bredeweg, J. Goda, T. Grove, D. Hayes, K. Jackman, G. McKenzie, and W. Myers, “Reaction rate, fission product yield, and Rossi-alpha measurements using a HEU metal, copper reflected critical assembly,” *Journal of Nuclear Science and Engineering*, **52**, pp. 1018-1025 (2015).
- [6] R. Sanchez, T. Grove, G. McKenzie, J. Goda, J. Bounds, T. Cutler, and D. Hayes, “Prompt neutron decay constants in a highly enriched uranium-lead copper reflected system,” *Proceeding of 2016 ANS Winter Meeting and Technology Expo*, Las Vegas, Nevada.
- [7] G. McKenzie, J. Bounds, T. Cutler, T. Grove, D. Poston, and R. Sanchez, “ Prompt neutron decay constant measurements on the KRUSTY cold critical configuration,” *Proceeding of 2018 ANS Winter Meeting and Technology Expo*, Orlando, Florida.
- [8] G. McKenzie, T. Cutler, J. Goda, T. Grove, J. Hutchinson, and R. Sanchez, “ Prompt neutron decay constant measurements on a lead moderated, copper reflected weapons grade plutonium system,” *Proceeding of ANTPC 2018*, Orlando, Florida.
- [9] F. de Hoffman, “Statistical fluctuations in the water boiler and time dispersion of neutrons emitted per fission,” *Los Alamos Technical Report*, Los Alamos, New Mexico (1944).
- [10] G. McKenzie, “Limits on subcritical reactivity determination using Rossi- α and related methods,” *University of Illinois PhD Dissertation*, Urbana, Illinois, USA (2018).
- [11] G. McKenzie, J. Goda, T. Grove, and R. Sanchez, “Rossi-alpha for a thermal system: Comparison of experiment and calculation,” *Los Alamos Technical Report*, Los Alamos, New Mexico (2017).
- [12] G. McKenzie, “Modern Rossi-alpha Measurements,” *University of Illinois MS Thesis*, Urbana, Illinois, USA (2015).